

UK EPR	Title: PCSR – Sub-chapter 8.3 – Nuclear Island Power Supply	
	UKEPR-0002-083 Issue 06	
	Total number of pages: 47	Page No.: I / V
Chapter Pilot: E. PILOQUET		
Name/Initials <i>EP. Loquet</i> Date 13-11-2012		
Approved for EDF by: A. MARECHAL		Approved for AREVA by: G. CRAIG
Name/Initials <i>A. Se. Marechal</i> Date 21-11-2012		Name/Initials <i>G. Craig</i> Date 21-11-2012

REVISION HISTORY

Issue	Description	Date
00	First issue for INSA information	11.12.07
01	Integration of technical and co-applicant review comments	26.04.08
02	PCSR June 2009 update: <ul style="list-style-type: none"> – Clarification of text – Integration of reference mapping. – Update of system description consist with December 2008 design freeze. – Single line diagram in English included. 	23.06.09
03	Consolidated Step 4 PCSR update: <ul style="list-style-type: none"> - Minor editorial changes - Update and addition of references - Clarification of text - Update consistent with Sub-chapter 3.2 (§0.3.1, §3.1, §5.4.1, new §7.2.1) - Section 0.3.2 “Technical directives” removed (not applicable) - Details added on protection against the effects of explosions due to electrical faults (§0.3.2) - Voltage control requirements updated (§1) - Indications of faults locally, on the PICS and alarms added (§5.1.3, §5.2.3, §5.3.3, §5.4.3 and §6.3) - Protection against unscheduled diesel start-up during maintenance (§5.1.5) - Information added on redundancy of supply, battery sizing and arrangements for battery charging (§5.2.1, §5.2.2, §5.2.3), - Information added on tests, inspection and maintenance (§5.4.5) - New section 7 added on qualification of electrical equipment 	31.03.11

Continued on next page

UK EPR		
	Title: PCSR – Sub-chapter 8.3 – Nuclear Island Power Supply	
	UKEPR-0002-083 Issue 06	Page No.: II / V

REVISION HISTORY (Cont'd)		
Issue	Description	Date
04	Consolidated PCSR update: <ul style="list-style-type: none"> - References listed under each numbered section or sub-section heading numbered [Ref-1], [Ref-2], [Ref-3], etc - Minor editorial changes - Clarification of text (§0.3.2, §1, §5.1.1, §5.1.2, §5.1.3, §5.1.5, §5.2.1.1, §5.2.3.1) - Inclusion of description of levels of defence in depth related to the electrical system in new §0.3 - Inclusion of new §0.4 linking to report 17074-709-000-RPT-0002, Issue 03 (CAE document) - Former sections 5.2, 5.3 and 5.4 restructured as sub-sections of §5.2 (Uninterruptible Power Supply); previous §5.2 retitled §5.2.1, "2-Hour Uninterruptible Power Supply"; previous §5.3 is now §5.2.2; and previous §5.4 retitled §5.2.3 "Severe Accident Dedicated 12-Hour Uninterruptible Power Supply" - Other changes for consistency with report 17074-709-000-RPT-0002, Issue 03 (CAE document) (§0.3.1, §1, §2.1, §2.2, §2.4, §3.1, §3.4, §4, §5.2.1, §5.2.3, §7.2, §7.2.2.3, §7.2.3) 	21.08.12
05	Consolidated PCSR update: <ul style="list-style-type: none"> - Update of reference 17074-709-000-RPT-0002 (CAE document) to Issue 05 (§0.4) - Minor wording or typographical changes (§0.2, §0.3, §0.3.1, §1, §4, §5.2.3.2, §5.2.3.3, §6.5, Figure 2) - Clarification of text (§2.4) 	22.10.12
06	Consolidated PCSR update: <ul style="list-style-type: none"> - Addition of introductory paragraph to include design changes to electrical systems to address potential common cause failure of a voltage level - Minor correction to Sub-chapter 8.3 – Figure 2 	21-11-2012

UK EPR		
	Title: PCSR – Sub-chapter 8.3 – Nuclear Island Power Supply	
	UKEPR-0002-083 Issue 06	Page No.: III / V

Copyright © 2012

**AREVA NP & EDF
All Rights Reserved**

This document has been prepared by or on behalf of AREVA NP and EDF SA in connection with their request for generic design assessment of the EPR™ design by the UK nuclear regulatory authorities. This document is the property of AREVA NP and EDF SA.

Although due care has been taken in compiling the content of this document, neither AREVA NP, EDF SA nor any of their respective affiliates accept any reliability in respect to any errors, omissions or inaccuracies contained or referred to in it.

All intellectual property rights in the content of this document are owned by AREVA NP, EDF SA, their respective affiliates and their respective licensors. You are permitted to download and print content from this document solely for your own internal purposes and/or personal use. The document content must not be copied or reproduced, used or otherwise dealt with for any other reason. You are not entitled to modify or redistribute the content of this document without the express written permission of AREVA NP and EDF SA. This document and any copies that have been made of it must be returned to AREVA NP or EDF SA on their request.

Trade marks, logos and brand names used in this document are owned by AREVA NP, EDF SA, their respective affiliates or other licensors. No rights are granted to use any of them without the prior written permission of the owner.

Trade Mark

EPR™ is an AREVA Trade Mark.

For information address:



AREVA NP SAS
Tour AREVA
92084 Paris La Défense Cedex
France



EDF
Division Ingénierie Nucléaire
Centre National d'Équipement Nucléaire
165-173, avenue Pierre Brossolette
BP900
92542 Montrouge
France

UK EPR		
	Title: PCSR – Sub-chapter 8.3 – Nuclear Island Power Supply	
	UKEPR-0002-083 Issue 06	Page No.: IV / V

TABLE OF CONTENTS

- 0. SAFETY REQUIREMENTS**
 - 0.1. SAFETY FUNCTIONS**
 - 0.2. SAFETY FUNCTIONAL REQUIREMENTS**
 - 0.3. DESIGN REQUIREMENTS**
 - 0.4 SAFETY CASE RELATIONSHIP**
- 1. SYSTEM ARCHITECTURE**
- 2. EMERGENCY DIESEL GENERATORS**
 - 2.1. OPERATING ROLE**
 - 2.2. DESIGN BASIS**
 - 2.3. SYSTEM DESCRIPTION – DESIGN PARAMETERS**
 - 2.4. OPERATIONAL REQUIREMENTS**
 - 2.5. TESTS, INSPECTION AND MAINTENANCE**
- 3. ULTIMATE DIESEL GENERATORS**
 - 3.1. OPERATING ROLE**
 - 3.2. DESIGN BASIS**
 - 3.3. SYSTEM DESCRIPTION – DESIGN PARAMETERS**
 - 3.4. OPERATIONAL REQUIREMENTS**
 - 3.5. TESTS, INSPECTION AND MAINTENANCE**
- 4. DIFFERENCES BETWEEN EMERGENCY DIESEL GENERATORS AND ULTIMATE DIESEL GENERATORS**
- 5. EMERGENCY POWER SUPPLIES**
 - 5.1. MEDIUM AND LOW VOLTAGE INTERRUPTIBLE EMERGENCY POWER SUPPLIES**
 - 5.2. UNINTERRUPTIBLE POWER SUPPLY**

UK EPR		
	Title: PCSR – Sub-chapter 8.3 – Nuclear Island Power Supply	
	UKEPR-0002-083 Issue 06	Page No.: V / V

6. NORMAL ELECTRICAL DISTRIBUTION SYSTEM

6.1. OPERATING ROLE

6.2. DESIGN BASIS

6.3. SYSTEM DESCRIPTION – DESIGN PARAMETERS

6.4. OPERATIONAL REQUIREMENTS

6.5. TESTS, INSPECTION AND MAINTENANCE

7. IMPLEMENTATION OF QUALIFICATION OF ELECTRICAL EQUIPMENT FOR NORMAL AND ACCIDENTAL CONDITIONS

7.1. INTRODUCTION

7.2. IMPLEMENTATION OF QUALIFICATION

SUB-CHAPTER 8.3 - NUCLEAR ISLAND POWER SUPPLY

A number of design changes will be implemented for the electrical systems to address the potential for Common Cause Failure (CCF) of the electrical supplies, by adding diversity in the voltage levels used to supply certain systems.

These design changes are not included in the description of the electrical systems provided in this sub-chapter or in Sub-chapter 8.6. The incorporation of these design changes into the safety case is described in section 9 of Sub-chapter 16.4, and the design changes will be fully incorporated into this sub-chapter as part of the detailed design during the site licensing phase.

0. SAFETY REQUIREMENTS

0.1. SAFETY FUNCTIONS

As a support system, the power supply to the nuclear island does not directly fulfil one of the three safety functions.

However, it provides power to safety equipment required for:

- Reactivity control,
- Removal of residual heat,
- Containment of radioactive substances.

0.2. SAFETY FUNCTIONAL REQUIREMENTS

The nuclear island's emergency power supply is required to supply power to the loads that perform safety functions, within acceptable static and dynamic voltage limits, in all operating modes and transient conditions, i.e.

- Operation at power,
- Power supply by the main generator (house load) after load reduction,
- Power supply by the main grid connection,
- Power supply by the auxiliary grid connection,
- Power supply by on-site emergency power sources (emergency diesel generators, EDGs (also referred to as main diesel generators within the PCSR)),
- Power supply by on-site ultimate emergency power sources (ultimate diesel generators, UDGs (also referred to as station black out diesel generators within the PCSR))

- Power supply by severe accident dedicated batteries (after loss of all off-site and on-site AC sources),
- During and after external hazards.

The reliability and availability requirements of the emergency power supply are such that it is not a determining factor in the unavailability of the systems to which it supplies power. This is supported by the reliability data presented in Probabilistic Safety Assessment (PSA) Sub-chapter 15.1. Nevertheless, the PSA highlights the importance of particular electrical supplies, and the risk contribution from the unavailability of certain power supply equipment is outlined in the PSA conclusion in Sub-chapter 15.7.

0.3. DESIGN REQUIREMENTS

In accordance with the defence in depth concept defined in Sub-chapter 3.1, the design of the electrical system incorporates five levels of defence:

- Level 1 addresses the design of all parts of the electrical system in compliance with its design basis, including the control of voltages;
- Level 2 covers current and insulation monitoring and also the switchover to the auxiliary grid connection upon loss of the main grid connection (PCC-1 event);
- Level 3 addresses the response to Loss Of Off-site Power (LOOP) (PCC-2 to PCC-4 events). For such events, the EDGs and 2-hour batteries are used as the on-site sources of power for the electrical loads required in response to the events;
- Level 4 applies to risk reduction scenarios such as LOOP with failure of all EDGs (RRC-A sequence) and total loss of AC sources (RRC-B sequence). As applicable to the sequence, either the UDGs and 2-hour batteries, or the 12-hour batteries, are used as the on-site sources of power for the electrical loads required in response to the sequences;
- Level 5 is aimed at contribution to on-site management of identified low probability high consequence fault sequences and at mitigation of the radiological consequences of potential releases of radioactive materials that may result from accident conditions.

0.3.1. Requirements arising from Safety Classification

- Requirement 1: Safety classification

The power supply must be classified according to the classification indicated in Sub-chapter 3.2. Part 2 of the System Design Manuals (SDMs) defines the safety function category and safety class for each system.

- Requirement 2: Single failure criterion (active and passive)

The Single Failure Criterion (SFC) is applied consistent with the architecture requirements defined in Sub-chapter 3.2. The SFC is addressed in Part 2 of the SDMs. During site licensing, compliance with the SFC will be demonstrated.

- Requirement 3: Emergency power supply

The emergency power supply system is arranged into four independent divisions. Each division includes an Emergency Diesel Generator (EDG) and an electrical distribution system consisting of 10 kV, 690 V and 400 V AC switchboards to supply power to the safety-related auxiliaries.

In each division, an Uninterruptible Power Supply (UPS) provides two uninterruptible supplies in parallel (220 V DC and 400 V AC). It guarantees electrical power with a 2-hour capacity at full load for the Instrumentation and Control (I&C) systems, the switchboard control supplies and the actuators for valves in the fluid system. The UPS also enables automatic start of the EDGs and maintains plant safety until the interruptible power supplies are restored.

The ultimate emergency power supply system is made up of two Ultimate Diesel Generators (UDGs) with a 24-hour capacity at full load that can supply the 690 V switchboards and UPS of Division 1 and 4. The 2-hour UPS provides power to enable manual start-up of the UDGs from the Main Control Room (MCR).

In the event that the EDGs and UDGs fail and the 2-hour UPS is exhausted, the severe accident dedicated UPS, with a 12-hour capacity at full load, supplies electrical power to the equipment involved in the management of severe accidents.

- Requirement 4: Qualification according to operating conditions

The electrical distribution system must be qualified to fulfil its safety role and to withstand the environmental conditions to which it is subjected when fulfilling its mission in accordance with Sub-chapter 3.6.

- Requirement 5: Periodic tests

Periodic tests must be performed on safety classified systems in order to assure their availability with a sufficient confidence level.

The use of testing equipment is outlined in the AFCEN RCC-E code [Ref-1]. The equipment to perform periodic testing is tested itself to ensure it is performing correctly.

0.3.2. Hazards

See the tables in Sub-chapters 13.1 and 13.2 that present the list of hazards taken into account in the design.

Concerning the effects of explosion due to explosion faults, ventilation or air exhaust ports together with the side ports of the doors and escutcheon plates are arranged so that the gas or vapour releases are not directed towards the operators performing operations and located in the immediate vicinity of the equipment (e.g. the High Voltage (HV) switchgear, water tanks, compressed air for diesel start reservoirs). The switchboards are designed to meet the internal arc test.

0.4. SAFETY CASE RELATIONSHIP

A Claims Arguments and Evidence (CAE) Document [Ref-1] gives additional information to that presented in this sub-chapter. This presents the requirements on the UK EPR electrical system as claims on the safety roles and capabilities of the electrical architecture, systems and equipment. These claims are supported by arguments and evidence. The evidence is either in the PCSR itself or in documents that support the PCSR.

The links between [Ref-1] and the PCSR Chapter 8 will be provided within [Ref-1].

1. SYSTEM ARCHITECTURE

The nuclear island's power supply system, which is organised into four independent divisions, includes:

- a normal power supply for all the non-safety-related loads located in the nuclear island's buildings;
- an emergency power supply for all safety-related loads of the unit, that includes:
 - 10 kV EDGs in all four divisions to back up the LHi switchboards;
 - 2-hour UPS in all four divisions for the I&C system, the control supplies for the electrical switchboards and all the other loads that must remain live during the start-up of the EDGs;
- an ultimate emergency power supply to the actuators required in a Station Black Out situation that includes 690 V UDGs in division 1 to back up switchboards LJA/K and in division 4 to back up switchboards LJN/D;
- a severe accident dedicated 12-hour UPS in divisions 1 and 4 to support the management of such accidents in the event of a LOOP and loss of all on-site emergency power supplies; and
- a power supply to the rod control mechanisms.

The interfaces between the conventional island and the nuclear island are as follows:

- The electrical distribution system on the nuclear island is supplied with power from the electrical distribution system on the conventional island and can be disconnected from it by opening circuit breakers on the nuclear island when power is supplied by the emergency diesel generators.
- The main 10 kV power supply systems on the nuclear island are connected to the normal power supply system on the conventional island via 10 kV circuit breakers located on the conventional island that are permanently closed except in the event of clearance of an electrical fault or maintenance.
- The conventional island emergency power supply system can be re-supplied with power from the 690 V emergency switchboards in two divisions on the nuclear island.
- The nuclear island rod control mechanisms are supplied with power from the conventional island 220 V DC electric power supplies located in sections 2 and 3.

The diagram below shows the connections between the two unclassified electrical buildings on the conventional island and the 4 divisions of the nuclear island.

Schematic diagram of the connections between the two unclassified electrical buildings (UEB) on the conventional island and the 4 divisions on the nuclear island

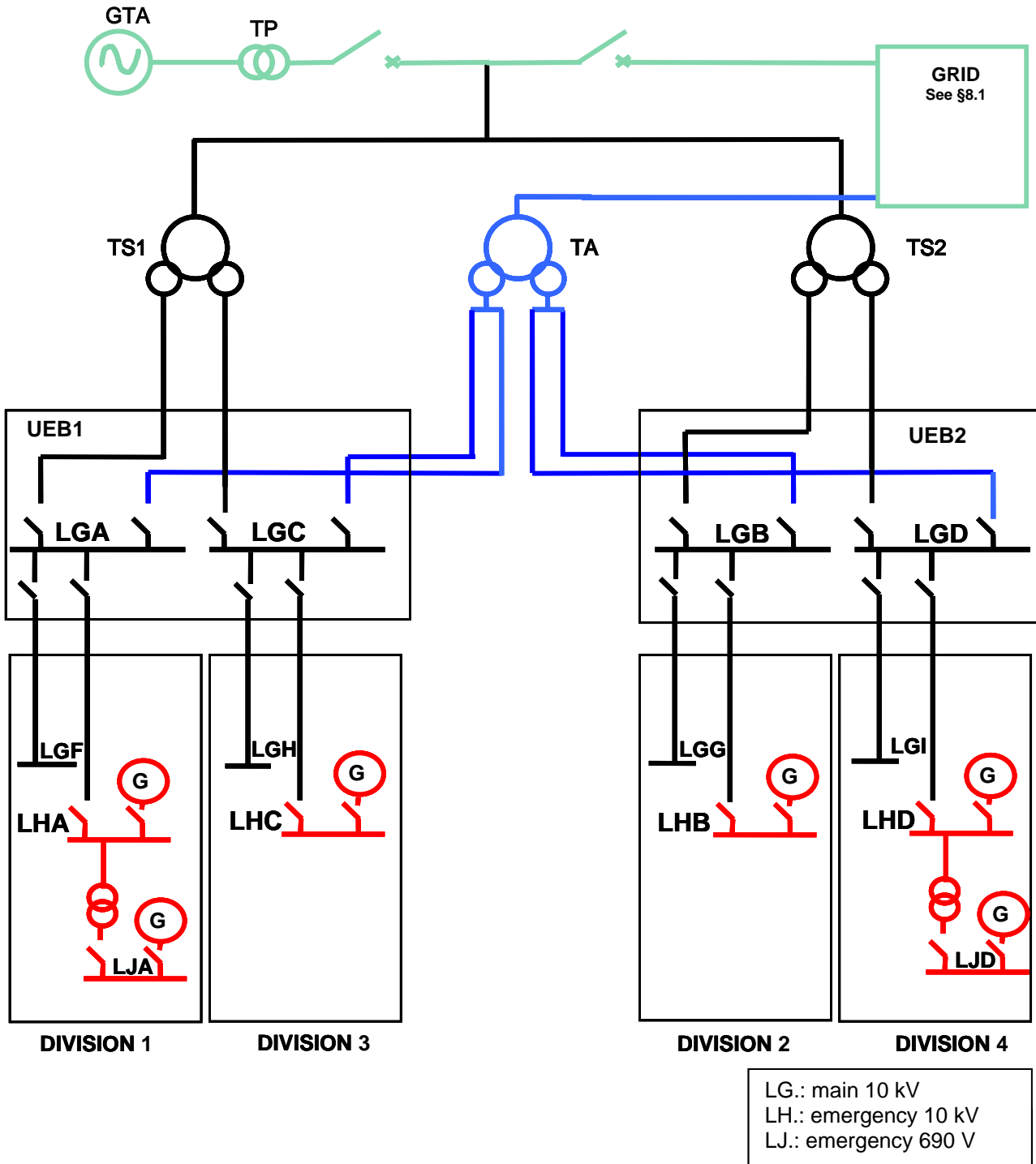

A line diagram of the EPR electrical distribution system is shown in Sub-chapter 8.3 - Figure 1. The electrical architecture of the nuclear island divisions is detailed in Sub-chapter 8.3 – Figure 2.

From Sub-chapter 8.3 - Figure 1, cross connections are provided between Nuclear Island (NI) divisions 1 and 2 and between NI divisions 3 and 4. There is no provision for cross connecting NI divisions 1 or 2 with NI divisions 3 or 4, ensuring separation and independence between the two pairs of NI divisions.

Consideration of abnormal operation of parts of the electrical system, including component faults and failure of interfacing systems, is addressed in the SDMs [Ref-1], [Ref-2] and [Ref-3].

The voltage requirements for the nuclear island electrical distribution system under various plant operating conditions are given in the table below. AC voltages are maintained within the permitted range in all operating modes, as defined in chapter D 2310 of the AFCEN RCC-E code [Ref-4] for power arising from external and internal sources. This is as measured across the terminals of auxiliaries when running, as defined in chapter D 2314 of the Book of Project Data [Ref-5]. Chapter D 2320 of the 'Book of Project Data' [Ref-5] defines the DC voltage characteristics for which the DC network equipment is designed, applicable at the terminals of auxiliaries in steady state mode.

Voltage requirements in the various operating conditions

Operating condition	Voltage control
Normal operation at power	<p>Voltage on the 10 kV busbars must be maintained within its permitted range by an on-load tap changer located on the primary side of the unit transformer with a set point of 1.05 Un no-load and Un full load.</p> <p>During the start-up of the largest drive, the voltage at its load terminals must not drop below 0.8 Un for more than 5 seconds.</p> <p>A short-term voltage drop does not cause:</p> <ul style="list-style-type: none"> - house load operation of the unit, - Step-down Transformer (TS) to Auxiliary Transformer (TA) switchover, - emergency diesel generator start-up. <p>All the High Voltage (10 kV) and Low Voltage (690 V) motors return to their normal speed within 5 seconds.</p>
Normal start-up and shutdown	Voltage controlled by the step-down transformer's voltage regulation.
House load operation	Voltage in the nuclear island power supply systems is controlled by the voltage regulation of the TS.
Switchover to auxiliary supply	Following transfer of load to the auxiliary supply, an on-load tap changer located on the TA primary maintains the voltage on the 10 kV busbar within its permitted range.

Operating condition	Voltage control
LOOP	<p>In the case of LOOP, the batteries (2-hour) supply power to the EDG I&C. Therefore, the voltage regulator inside the EDG I&C is always supplied.</p> <p>When an EDG is connected to the 10 kV emergency switchboard, the voltage delivered by the EDG to the switchboard is regulated by an automatic voltage regulator. This regulator supplies the current of the required excitation to permanently adjust the voltage generator to the set point (10 kV) between operation without actuators and operation with all actuators (nominal power).</p>
SBO (see section 3.1 below)	<p>After operating on battery and start-up of the UDGs, the voltage is maintained within its permitted range on the re-supplied switchboards by the voltage regulation of the UDGs.</p> <p>During start of the largest drive (ASG [EFWS] Emergency Feedwater System motor-driven pump), the voltage at its load terminals must not drop below 0.8 Un for more than 5 seconds.</p>

From chapter D 2313 of the AFCEN RCC-E code [Ref-4], the frequency ranges of power supplies from internal sources to the auxiliaries are the same as from external sources. That is as defined in chapter D 2312 of the Book of Project Data [Ref-5], except where the electrical system equipment is designed to withstand a one-off internally generated higher frequency condition.

Power balances are provided in the SDM Part 3.

The electrical system architecture is underpinned by a robust earth system (LTR) design. This is described in detail in PCSR Sub-chapter 8.4, section 2.

Substantiation of the electrical system equipment will demonstrate that it is suitable.

2. EMERGENCY DIESEL GENERATORS

2.1. OPERATING ROLE

The 10 kV emergency diesel generators restore the power supply in the event of LOOP when house load operation fails or is not possible.

In the event of LOOP, the start-up and connection of the diesel generator to the emergency switchboard is automatic (initiated by signals from the Protection System in response to monitoring of the LHi busbar voltage).

The emergency power supply systems supply safety classified loads, and loads important for unit availability.

The EDGs, via switchboards LJA/B/C/D and rectifiers, support the 2-hour UPS in all four divisions and the 12-hour UPS in divisions 1 and 4.

2.2. DESIGN BASIS

The 10 kV diesel generators [Ref-1] to [Ref-3] contain all the equipment required for the 10 kV power supply to loads required for the performance of the safety functions. The EDGs can operate at full load for 72 hours without refuelling. In back-up mode, each EDG supplies electrical power in accordance with the voltage and frequency criteria defined by the RCC-E [Ref-4].

The emergency diesel generator power requirement takes into account the allocation of loads on the busbars (including interconnected switchboards loads) and their use in reference incidents and accidents. The rated capacity of the diesel generator is determined from the reference accident with the highest power requirements [Ref-5].

2.3. SYSTEM DESCRIPTION – DESIGN PARAMETERS

See section 2 of Sub-chapter 9.5.

2.4. OPERATIONAL REQUIREMENTS

The emergency diesel generators are automatically started in the event of simultaneous loss of the two off-site power sources when house load operation fails or is unavailable, or in the event of malfunction on a main 10 kV busbar on the conventional island.

The emergency diesel unit is automatically started-up when the voltage on the emergency 10 kV busbar is lower than $0.8 U_n$ for more than 5 seconds. These values take into account the activation time of the TS/TA transfer switch and the longest possible transfer time. This also means that the start-up of a diesel unit can be prevented during the start-up phases of large motors such as a motor-driven feedwater pump or a primary pump.

The Protection System automatically starts up the diesel generators in the event of a loss of power from their respective emergency 10 kV busbar. It also ensures the disconnection of all emergency loads (this disconnection is necessary as breakers and contactors of safety actuators remain in position in case of LOOP), and handles their reconnection following a specified loading sequence, thus avoiding overload of the emergency diesel unit.

Periodic testing of the EDGs consists of testing complete safety functions including the start-up sequence logic and loading sequence programme of each EDG.

2.5. TESTS, INSPECTION AND MAINTENANCE

See section 2 of Sub-chapter 9.5.

3. ULTIMATE DIESEL GENERATORS

3.1. OPERATING ROLE

In the event of a Station Black Out (SBO) (i.e. LOOP and loss of the turbo-alternator unit combined with the loss of all the 10 kV EDGs) the 690 V power supply can be restored in divisions 1 and 4 by means of the 690 V ultimate diesel generators so as to supply power to the actuators required in such a situation.

The main duty of the 690 V ultimate diesel generators is to supply power to the two Emergency Feedwater System (ASG [EFWS]) pumps, the ventilation systems including the safety classified parts of the Annulus Ventilation System (EDE [AVS]), the nuclear island I&C systems, and the control room lighting.

The third Spent Fuel Pool Cooling (PTR [FPCS]) train, Containment Heat Removal (EVU [CHRS]) and SRU [UCWS] systems can also be supplied with power from the ultimate diesel generators.

The UDGs, via switchboards LJA/B/C/D and rectifiers, support the 2-hour UPS and 12-hour UPS in divisions 1 and 4.

3.2. DESIGN BASIS

The 690 V UDGs [Ref-1] to [Ref-3] contain all the equipment necessary for the supply of 690 V to the loads required in the event of a SBO in order to fulfil safety functions.

The UDGs' power requirement takes into account the allocation of loads on the busbars and their use [Ref-1] to [Ref-3].

One UDG is sufficient to protect against SBO and forms a completely independent unit with its own auxiliary systems.

The UDGs are of a different design from the 10 kV EDGs (see section 4).

3.3. SYSTEM DESCRIPTION – DESIGN PARAMETERS

See section 2 of Sub-chapter 9.5.

3.4. OPERATIONAL REQUIREMENTS

When a SBO occurs, the only power source immediately available is the batteries which have a 2-hour capacity. The two UDGs must therefore be started within 2-hour to supply power to the emergency 690 V switchboards.

The UDGs are normally started manually from the main control room. The coupling of the UDGs to the busbars, and the subsequent reconnection of the loads are also normally carried out from the main control room. If the UPS is unavailable, start-up and coupling of the UDGs are performed locally.

Periodic testing of the UDGs consists of testing complete safety functions including the start-up sequence logic and loading sequence programme of each UDG.

3.5. TESTS, INSPECTION AND MAINTENANCE

See section 2 of Sub-chapter 9.5.

4. DIFFERENCES BETWEEN EMERGENCY DIESEL GENERATORS AND ULTIMATE DIESEL GENERATORS

Common cause failure of the emergency diesel generators and the ultimate diesel generators can be caused by:

- The diesel generator and the related equipment (e.g. simultaneous failure of an identical component)
- The environment (e.g. fuel, temperature, operating conditions).

The strategy to combat the risk of common cause failure primarily rests on the high intrinsic reliability of the equipment.

From a design point of view, the following options have been adopted:

- A 'semi-fast' speed (1000 RPM or less) for the emergency diesel generators, based on good operational experience in France and Germany
- A 'fast' speed (more than 1000 RPM) for the ultimate diesel generators adapted to the required power level.

These options contribute to increasing the design and component differences, and offer a satisfactory diversification between the two types of diesel generators.

At the generic design stage, a definition of how diversification and redundancy are implemented to ensure the independence of the EDGs and UDGs on EPR Flamanville 3 (FA3) is provided in [Ref-1].

Finally, the choice of different suppliers further increases the design and component diversity between the different machines.

With regards to I&C systems, some measures are applied. For instance, the reloading of the emergency diesel generators is done automatically by the Protection System (PS) whereas it is done manually for the ultimate diesel generators by the standard I&C system from the Main Control Room.

With regards to environmental conditions, certain measures are applied in the design and operation. For example:

Design:

- Protection against the vent pipe corrosion in the event of ingress of water into the fuel or oil tanks.

- Preheat systems to protect against deterioration of the coolant.
- Installation of fuel transfer pump piping inside the buildings to protect against fuel freezing or grease congealing in the fuel transfer pump.

Operating conditions:

- To protect against bacteriological pollution:
 - Bactericidal treatment of the main fuel tanks,
 - Periodic monitoring of the fuel with physical and chemical analysis of samples.
- To protect against common cause failure due to accidental pollution or an error during fuel deliveries:
 - Emptying of a tanker into only one fuel tank,
 - Quality assurance of the fuel suppliers,
 - Monitoring during fuel delivery by physical and chemical analysis of a sample taken from the truck.
- Restriction of diesel operation at no-load to protect against dilution of the lubricating oil by fuel.
- Ensuring compatibility of cooling fluids with the pipework to avoid corrosion.
- Periodic tests at full load and preventive maintenance to avoid degradation of capability.
- Diversification of maintenance programmes between the emergency diesel generators and the ultimate diesel generators, re-qualification tests and tests at full load after maintenance operations to minimise the risk of simultaneous unavailability of the emergency diesel generators and the ultimate diesel generators following a common maintenance error.

Generally:

Account is taken of feedback of operating experience from French and German plant operation.

Conclusion:

The difference between the emergency diesel generators and the ultimate diesel generators in power and speed, as well as the measures described above, means that common cause failure between the four emergency diesel generators and the two ultimate diesel generators can be disregarded in accident analysis.

5. EMERGENCY POWER SUPPLIES

5.1. MEDIUM AND LOW VOLTAGE INTERRUPTIBLE EMERGENCY POWER SUPPLIES

5.1.1. Operating Role

The interruptible emergency power distribution system supplies power to safety-related loads and loads that are important for unit availability within the acceptable static and dynamic limits for these loads.

5.1.2. Design Basis

The interruptible emergency power supply system contains all the equipment to enable emergency power to be supplied to the required loads.

The loads supplied by the interruptible emergency power distribution are designed to operate in the normal and exceptional ranges of voltage and frequency and must maintain their integrity in the normal, exceptional and accidental ranges of voltage and frequency in accordance with the operating ranges defined in the RCC-E [Ref-1].

5.1.3. System Description – Design Parameters

System Description:

In each division, the emergency power supply system contains the following equipment:

- A 10 kV emergency distribution system [Ref-1] [Ref-2].
- A 690 V emergency distribution system [Ref-3] [Ref-4] supplied via transformers for the power drives, the largest being about 500 kW. There are two main 690 V emergency distribution systems by division, each one supplied via a transformer. In divisions 1 and 4, this architecture guarantees satisfactory voltage response to transients such as transformer switchover. In divisions 2 and 3, one distribution system is dedicated to the cross-connections.
- A 400 V AC emergency distribution system regulated and supplied via a regulating transformer for classified motorised valves [Ref-5] [Ref-6].
- A 400 V AC emergency distribution system [Ref-7] [Ref-8] supplied via a transformer for the power supply of motorised drives or other machines and the emergency pressuriser heaters; and a 400 V AC emergency sub-distribution system [Ref-7] [Ref-8] for the emergency lighting and power supply to other loads necessary during maintenance.

Each of the 10 kV switchboards of the emergency distribution system on the nuclear island is supplied by a normal power supply switchboard on the conventional island and can be disconnected from it by opening a switching device on the nuclear island in the event of a requirement to supply power from on-site power sources. The conventional island and nuclear island power supplies are physically separated and are installed in different buildings.

The low voltage emergency switchboards are supplied with power by the 10 kV emergency switchboards via a 10 kV circuit breaker that fulfils an electrical protection function in the event of a fault on the low voltage switchboard.

The dry type low voltage transformers are directly connected to the low voltage busbar (except for the distribution systems supplied by the ultimate diesel generators).

Classified motorised valves (except for those that require an UPS, such as the internal containment isolation valves according to section 5.2.1) are supplied by a 400 V AC power supply that is regulated via a constant-voltage transformer that guarantees a constant voltage within the limits permitted for these drives during all voltage transients.

The faults are indicated locally and on the Process Information and Control System (PICS), and an alarm is triggered when an action is necessary.

Design parameters:

The switchboards are metal clad with withdrawable switchgear. They are equipped with an earthing device and a voltage measuring cubicle.

Each withdrawable cubicle can take three positions: in operation, testing, or withdrawn.

Each cabinet is separated into distinct compartments for connecting cables, the switching device, the busbar and the I&C system.

The outgoing sections for motors or non-smart motorised valves are equipped with a contactor-fuse combination, the outgoing sections for high power motors are equipped with circuit breakers, and the outgoing sections that supply power to the sub-switchboards utilise fused switch-disconnectors.

The electrical characteristics (voltages, nominal currents and short-circuit currents) of the protection equipment and 10 kV switching device are identical in the nuclear island and the conventional island, the two systems being coupled together.

The short-circuit resistance values of the busbars are compliant with the chapter C 2000 of the AFCEN RCC-E code [Ref-9].

5.1.4. Operational Requirements

The 10 kV emergency switchboards receive their power supply from main 10 kV switchboards on the conventional island, during the unit's normal start-up and shutdown, during unit outages, and in the event of an accident.

In the event of LOOP coupled with the failure of the house load operation and of the transformers switchover, power is supplied to the emergency loads by the emergency diesel generators.

In the event of a SBO, no 10 kV drive is required, two of the four pumps of the emergency feed water supply system that feed the steam generators are supplied by the ultimate diesel generators.

5.1.5. Tests, Inspection and Maintenance

The 400 V AC regulated switchboards of divisions 1 and 2, and similarly those of divisions 3 and 4, can be linked via an interconnection that enables unit maintenance operation while respecting the SFC. In particular, the containment isolation function is maintained.

The 400 V AC emergency sub-distribution boards supply loads such as emergency lighting and the motorised systems required during preventive maintenance operations. The interconnections between the sub-distributions of divisions 1 and 2, and 3 and 4 respectively, are closed by manually-controlled fused isolators. They will only be used during maintenance.

Two 690 V emergency sub-distribution boards are provided in divisions 2 and 4 for the power supply to two spent fuel pool cooling system pumps (PTR [FPCS]) during unit shutdown. These sub-distribution boards can receive their power supply from their own division or from neighbouring divisions after manual switchover, provided appropriate interlock requirements are met.

The pump of the third PTR [FPCS] train receives its power supply from a dedicated sub-distribution board in division 1 that can be re-supplied with power after manual changeover, provided appropriate interlock requirements are met.

See Sub-chapter 8.3 - Figure 2: interconnections 3 and 5 for the 400 V AC emergency sub-distributors, interconnection 2 for the 690 V emergency sub-distributors.

During maintenance operations (in particular following electrical fault), to protect the operators from an accident due to an unscheduled start-up of the diesel, a mechanical interlock is installed on the air entry valves (venting start-up air system). In addition, the diesel circuit breaker is open and racked-out and the emergency switchboard is connected to electrical ground.

5.2. UNINTERRUPTIBLE POWER SUPPLY

5.2.1. 2-Hour Uninterruptible Power Supply

5.2.1.1. Operating role

The UPS system supplies power to connected loads under voltage conditions within the permitted static and dynamic limits for these loads during all possible operating modes and the corresponding transients.

The UPS mainly supplies power to:

- the AC/DC and DC/DC converters for supplying the I&C cabinets. These cabinets are supplied from 2 redundant uninterruptible feeders;
- the AC/DC and DC/DC converters for the control voltage to the electrical switchboards. This control voltage is supplied from 2 redundant uninterruptible sources;
- all equipment required for the human-machine interface such as computers, screens, touch screens in the control room and all other I&C equipment that requires 230 V uninterruptible AC,

- actuators in fluid systems such as:
 - isolation valves inside the containment;
 - control valves and solenoid valves; and
- emergency escape lighting and other systems such as access control and fire detection.

The dual uninterruptible feeders are supplied by the same 220V DC, 2-hour backed-up switchboard in its division in normal operation.

For the supply of functions fed by 2-hour batteries, the two upstream switchboards are LA_i (where the 'i' is for A, B, C or D) and LV_j (where the 'j' is for A, B, C, D).

[Ref-1] and [Ref-2] identify the operating conditions when the 2-hour batteries are needed and provide overviews of the supported systems.

5.2.1.2. Design basis

The UPS system contains all the electrical equipment needed to produce and distribute:

- 230 V and 400 V AC to the I&C cabinets and to the safety-related and operational drives of the nuclear island that require an UPS, including that required for start-up of the emergency diesel generators,
- 220 V DC to the I&C cabinets.

The loads supplied by the UPS system are designed to operate in the normal and exceptional ranges of voltage and frequency and must maintain their integrity in the normal, exceptional and accidental ranges of voltage and frequency in accordance with the operating ranges defined in the RCC-E [Ref-1].

The allocation of loads to the busbars takes into account the redundancy requirements of the safety systems, the power requirements of the static converters and batteries.

The architecture of the supply to the I&C cabinets and for the switchgear actuation enables the use of redundant and diverse components and enables it to reduce the dependence on the availability of the inverters.

The combination of rectifier / battery / inverter is protected against internal overvoltages. This protection acts on the rectifier and guarantees the integrity and the availability of the battery and the inverter.

The batteries sizing takes into account the switchboards to be supplied along with the instant of supply of some particular actuators (containment valves) and the duration of the supply by batteries in reference scenarios. Concerning the design sizing current, significant intermittent loads (containment valves for example) are taken into account by adding current peaks to basis consumption. The power of intermittent loads is reduced by an appropriate simultaneity factor prior to inclusion in the load profile. Based on the consumption of permanent and intermittent loads, the evolution of the current for the different scenarios previously identified is determined and a 10% margin is applied to the sizing current.

The batteries are sized to guarantee the required supply duration at the end of their service life [Ref-2] at minimum room temperature for the required load profile.

The batteries used for the UPS are lead-acid batteries of diverse manufacture (from different suppliers and different factories) between divisions 1-2 and 3-4.

5.2.1.3. System description – design parameters

System description:

In each division, the UPS system [Ref-1] to [Ref-4] includes the following equipment:

- An uninterruptible 230/400 V AC main distribution system,
- An uninterruptible 230/400 V AC sub-distribution system,
- A rectifier/charger that supplies power to the inverter and charges the battery,
- A 220 V DC battery,
- A 220 V DC distribution system to which the battery is connected,
- A three-phase inverter with static contactor to supply power to the 230/400 V AC main distribution system from the 220 V DC provided by the charger/battery combination.

In each division, the uninterruptible 230/400 V AC electrical distribution system receives its power supply from the 690 V emergency distribution system through the rectifier/charger combination, the buffer battery and the three-phase inverter (see Sub-chapter 8.3 - Figure 2).

In the event of loss of the inverter, the uninterruptible 230/400 V AC electrical distribution system receives its power supply from the regulated 400 V AC supply of the same division via the inverter's static contactor.

The inverter output voltage is synchronised with that of the regulated 400 V distribution system so that changeover can take place without loss of power.

The I&C cabinets receive their power supply from the converters that convert the upstream voltage to the required voltage level (between 24 and 48 V DC). Each converter is able to supply power to an I&C cabinet unit. These converters are installed close to the I&C cabinets in the electrical equipment rooms.

Each I&C cabinet receives its power supply from two diode decoupled power supply sources, namely the uninterruptible 220 V DC distribution system and the uninterruptible 230/400 V AC sub-distribution system of the same division. It is also possible to install the converters directly in the I&C cabinets.

The control voltage of the electrical switchboards is also supplied from the 220 V DC distribution systems and the 230/400 V AC sub-distribution systems via isolation diodes. The power supply is rectified to the required voltage level, the diodes performing the isolation between the two power supply sources.

The power supply of solenoid valves, which require 125 V DC, is derived from the UPS.

Faults are indicated locally and on the PICS, and an alarm is triggered when an action is necessary.

Design parameters:

The static converters are installed in steel plate cabinets. The inverter part has an electronic transfer device (static contactor) that guarantees a transfer of the UPS to the regulated 230/400 V AC network in the event of inverter failure.

The lead-acid batteries are made up of cells mounted on a chassis in grouped transparent sealed tanks with their own measuring system that measures each cell voltage.

The 220 V DC rectifiers are of the three-phase static type, installed in steel plate cabinets. The uninterruptible supply switchboards are installed in metal-clad cabinets with withdrawable switchgear. They are divided into compartments for incoming cables, busbars and switching devices. Each withdrawable switchgear unit can take three different positions: operation, testing and withdrawn.

The outgoing sections that supply power to the motorised actuators are equipped with contactor-fuse combinations; the outgoing cables are equipped with fused switch isolators.

Concerning the battery charging, typical voltage is $238\text{ V} < U < 242\text{ V}$. The boost charge is realised with disconnected loads only. The batteries must be charged for a minimum of 10 hours (in order to obtain a homogenous charge of all the cells) and a maximum of 24 hours.

5.2.1.4. Operational requirements

The uninterruptible 230/400 V AC switchboards receive their power supply from the emergency 690 V switchboards via the charger/battery/inverter unit. In the event of loss of the inverter, the uninterruptible switchboards receive their power supply from the regulated 230/400 V AC via the static contactor and the battery remains available to supply the I&C cabinets and the control supplies to the switchboards via the 220V DC distribution systems.

As long as the emergency 690 V is available, the power supply is ensured via the charger/inverter, and the battery is kept on a floating charge by the rectifier.

In the event of LOOP or a SBO, in each of the four divisions, the systems that receive their power supply from the uninterruptible distribution still receive their power supply from the battery until the start-up/coupling of their division's diesel generators.

A manual by-pass from the regulated 400 V AC distribution can be used to enable preventive maintenance of the battery, e.g. charging at a higher voltage, with the unit in operation or during unit shutdowns.

In the event of overvoltage at the input of the UPS system (rectifier / battery / inverter combination) the rectifier is tripped and the systems supplied by the UPS remain supplied by the batteries.

In order to confirm that the batteries can achieve their required safety function, their capacity is tested periodically.

Design of power supply to containment isolation valves:

Penetrations for the mechanical systems are equipped with isolation valves. Where isolation is achieved by two motorised valves, one is located inside and the other outside the containment. The internal isolation valves have an uninterruptible 400 V AC power supply; the external valves have a regulated 400 V AC power supply and can be re-supplied with power from 12-hour batteries (see section 5.2.3). For these switchboards, interconnections between divisions 1 and 2 and between divisions 3 and 4 (See Sub-chapter 8.3 - Figure 2: interconnections 3) are provided and will be used when maintenance is being carried out on an emergency diesel generator.

Sub-chapter 8.3 – Figure 4 shows the allocation of valves to electrical divisions. It can be seen that the containment isolation is guaranteed in the event of LOOP while maintenance is being performed on an EDG or on a battery, even if there is a single failure.

5.2.1.5. Tests, Inspection and Maintenance

While the battery is being charged at high voltage, the rectifier and battery are disconnected from the system by means of a manual by-pass switch. In this case, loads still receive their power from the by-pass (see the figure below).

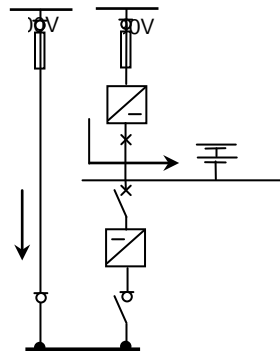

Each division is equipped with an uninterruptible sub-distribution board that only supplies power to the second outgoing section of each double power supply load of a division. This sub-distribution board can receive its power from the main uninterruptible distribution of its division or after manual switchover, from the main uninterruptible distribution of a neighbouring division (see the following figure: during preventive maintenance of division 1, the sub-distribution system of division 1 is supplied by the main distribution system of division 2).

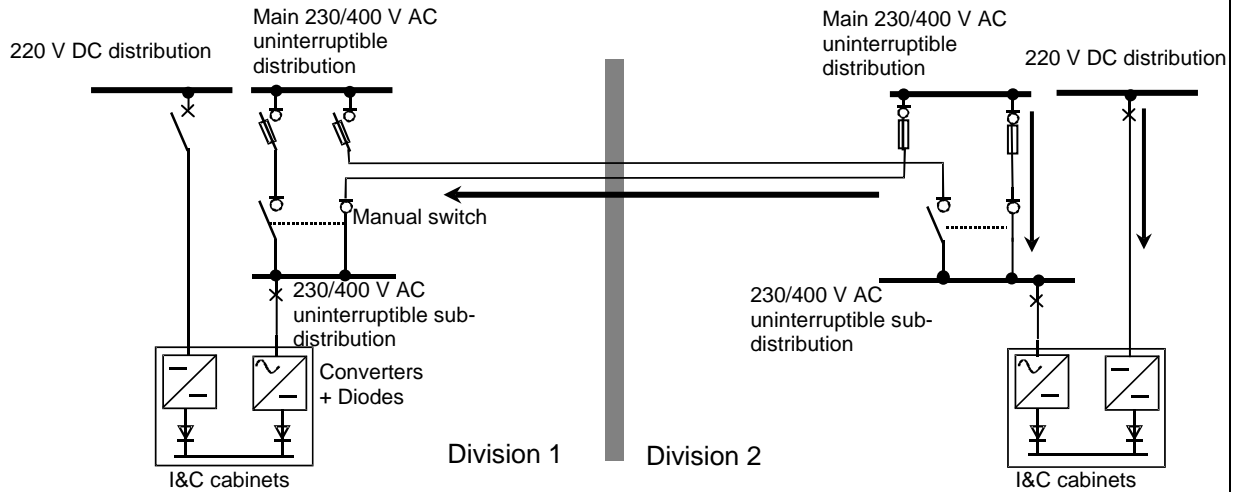

The connection to the neighbouring division is only made during unit maintenance or during unit outages.

This enables:

- The operation of the 4 I&C divisions during preventive maintenance in a division,
- Battery back-up of the I&C cabinets and their loads while a battery in a division is being charged at high voltage,
- The performance of battery discharge tests with the unit in operation.

5.2.2. Power Supply to Rod Control Mechanisms

5.2.2.1. Operating role

The power supply system for the rod control mechanisms distributes 220 V DC to all the rod control mechanisms.

5.2.2.2. Design basis

The power supply system for the rod control mechanisms contains electrical equipment that enables the distribution of 220 V DC to the rod control mechanisms.

5.2.2.3. System description – design parameters

System description:

The power supply system for the rod control mechanisms is made up of two interconnected switchboards (LAL, -M) where the four Reactor Trip circuit breakers are installed in division 2 and 3 and of two switchboards (LAK, -N) located in divisions 1 and 4 for the supplying power to the rod control mechanisms (see Sub-chapter 8.3 – Figure 3).

The power supply is provided by the 220 V DC distribution system on the conventional island (trains 2 and 3), backed-up with a buffer battery [Ref-1] to [Ref-4].

The batteries supply power to the control rod mechanisms for the required duration of house load operation in order to prevent the reactor from shutting down automatically when transients occur on the unit network.

The faults are indicated locally and on the PICS, and an alarm is triggered when an action is necessary.

Design Parameters:

Each rod control mechanism is equipped with three coils, the fixed clamp coil, the mobile clamp coil and the mounted clamp coil that are activated in a specific sequence by the rod control system so as to achieve vertical motion. The rod control system requires individual control of each rod group, movement of one rod group or simultaneous operation of all the rods.

5.2.2.4. Operational requirements

The power supply system of the rod control mechanisms is supplied, via two cables designed with the total nominal current, by the DC distribution system at the output of the rectifiers/chargers in the divisions 2 and 3 of the conventional island. Each of these 220 V DC distributions systems is backed-up with a battery.

The reactor protection system initiates automatic reactor shutdown by opening:

- The Reactor Trip circuit breakers,
- The contactors of each rod group with a 2 out of 4 logic for each of the rod groups.

5.2.2.5. Tests, inspection and maintenance

The layout of the circuit breakers and contactors enables periodic tests to be performed with the unit in operation without causing the rods to fall.

5.2.3. Severe Accident Dedicated 12-Hour Uninterruptible Power Supply**5.2.3.1. Operating role**

The severe accident dedicated UPS system supplies power to connected loads under voltage conditions within the permitted static and dynamic limits for these loads, during all possible operational modes and corresponding transients.

The main duty of the severe accident dedicated 230/400 V AC UPS is to supply power to:

- The relief valve controls for the severe accident discharge line of the primary circuit,
- The AC/DC converters specific to the power supply for the I&C cabinets and the instrumentation used in severe accidents,
- The AC/DC converters for the control supplies to the electrical switchboards used in severe accidents,

- The control room indicators of use to the operator in managing and monitoring severe accidents,
- The external containment isolation valves,
- The EDE [AVS] (annulus ventilation system) safety classified parts (fans and heaters),
- The lighting system in the main control room dedicated to severe accidents.

For the supply of functions fed by 12-hour batteries, the two upstream switchboards are respectively LVP and LVS.

[Ref-1] identifies the operating conditions when the 12-hour batteries are needed and provides an overview of the supported systems.

5.2.3.2. Design basis

The UPS system contains all the electrical equipment required for the production and distribution of 230 V and 400 V AC for the management of a severe accident involving loss of all off-site and on-site power supplies.

The loads supplied by the severe accident dedicated UPS system are designed to operate in the normal and exceptional ranges of voltage and frequency and must maintain their integrity in the normal, exceptional and accidental ranges of voltage and frequency in accordance with the operating ranges defined in the RCC-E [Ref-1].

The batteries are sized to guarantee a 12-hour storage capacity at the end of their service life [Ref-2] [Ref-3].

Requirements and functional scenarios taken into account for sizing the 12-hour batteries; and the switchboards and the supported systems to be powered by the batteries under defined fault conditions are addressed in [Ref-4].

5.2.3.3. System description – design parameters

System Description

The severe accident dedicated UPS system is installed in divisions 1 and 4. Each of these divisions contains the following equipment:

- A 230/400 V AC distribution system [Ref-1] [Ref-2] that supplies the I&C cabinets and the control supplies to the electrical switchboards via AC/DC converters, and an outgoing feeder to the switchboard dedicated to the supply of the external containment isolation valves (divisions 1 and 4). From these switchboards, the switchboards dedicated to the supply of the external containment isolation valves in the divisions 2 and 3 can be re-supplied.
- A rectifier/charger that supplies power to the inverter and charges the battery,
- A battery,
- A connecting cabinet between the charger and the battery,

- A three-phase inverter to supply power to the 230/400 V AC switchboard from the 220 V DC provided by the charger/battery combination.

In divisions 1 and 4, the severe accident dedicated uninterruptible 230/400 V AC electrical distribution system receives its power supply from the 690 V emergency distribution system through the rectifier/charger set, the buffer battery and the three-phase inverter.

In the event of loss of the inverter, the severe accident dedicated uninterruptible 230/400 V AC electrical distribution system receives its power supply from the regulated 400 V AC distribution system of the same division via the inverter static contactor.

The inverter output voltage is synchronised with that of the regulated 400 V AC distribution system so that changeover can take place without loss of power.

The severe accident I&C cabinets receive their power supply from the rectifiers that convert the 230/400 V AC voltage to the required voltage level (between 24 and 48 V DC).

Each I&C cabinet receives its power supply from two diode decoupled power supply sources, namely the uninterruptible 220 V DC distribution system and the severe accident dedicated uninterruptible 230/400 V AC distribution system of the same division.

The control voltage of the switchboards of the severe accident dedicated UPS is supplied as described in section 5.2.1.3. In the event of total loss of electrical power, the switchboards used in this kind of severe accident are manually changed to auto-control mode.

Two connections between the uninterruptible 230/400 V AC switchboard and the switchboards that supply power to the external containment isolation valves that receive their power from the division, and the neighbouring division, are provided in order to allow for the operation of these valves when the only available sources are the severe accident dedicated batteries. These connections are only used in these conditions.

Faults are indicated locally and on the PICS, and an alarm is triggered when an action is necessary.

Design Parameters

The design parameters of the severe accident dedicated UPS equipment are similar to those of the uninterrupted power supply (see section 5.2.1.3 of this sub-chapter).

5.2.3.4. Operational requirements

The severe accident dedicated uninterruptible 230/400 V AC switchboards receive their power supply from 690 V switchboards via the dedicated charger/battery/inverter unit. In the event of loss of the inverter, the uninterruptible switchboards receive their power supply from the regulated 230/400 V AC via the static contactor and the 2-hour battery remains available to supply the I&C cabinets dedicated to severe accident via the 220 V DC distribution systems.

As long as the emergency 690 V is available, the power supply is ensured via the charger/inverter, and the battery is kept on a floating charge by the rectifier.

In the event of total loss of both off-site and on-site power, the systems that receive their power supply from the uninterruptible supplies are still supplied with power by the batteries that have a 12-hour storage capacity.

A manual connection from the 400 V AC regulated system can be used to enable preventive maintenance of the battery.

The switchboards that supply power to the external containment isolation valves receive their power from the 400 V AC regulated switchboard [Ref-1] [Ref-2]. Should there be a total LOOP and loss of on-site power, these switchboards can be supplied with power once again after the operator has manually switched the power supply to that of the severe accident dedicated UPS. In this case, each of the 12-hour batteries supplies the external containment isolation valves' switchboards.

The rectifier and the battery can be separated from the network by means of a manual by-pass in the event that the battery is being charged at high voltage. In this case, loads still receive their power from the by-pass system.

5.2.3.5. Tests, inspection and maintenance

The maintenance regime for the severe accident dedicated UPS system is likely to be based on the guidelines described in INPO AP-913 "Equipment Reliability Process" [Ref-1], and will use manufacturers' details of equipment, plus environmental qualification and operational experience to generate maintenance schedules in order to satisfy the requirements of the Nuclear Site Licence (predominantly, Licence Conditions 28 and 29). Maintenance regimes will be put in place as plant is commissioned and placed into service.

6. NORMAL ELECTRICAL DISTRIBUTION SYSTEM

6.1. OPERATING ROLE

The main electrical distribution system supplies power to the nuclear island operational loads.

6.2. DESIGN BASIS

The main electrical distribution system contains all the equipment that enables the power supply to the non-safety loads of the nuclear island.

6.3. SYSTEM DESCRIPTION – DESIGN PARAMETERS

System Description:

The main electrical power supply system contains the following equipment in each division:

- A 10 kV main distribution system [Ref-1] [Ref-2] that supplies power in particular to a primary motor-driven pump unit.
- In divisions 1 and 4, a 690 V main distribution system [Ref-3] [Ref-4] that receives power from the 10 kV main distribution system on the conventional island via a transformer, to supply power to the non-safety drives with power 500 kW or less.

- A 400 V AC main distribution system [Ref-5] [Ref-6] that receives power from the 10 kV main distribution system on the nuclear island via a transformer to power supply to operational loads and non-safety pressuriser heaters.
- A 400 V AC main sub-distribution system [Ref-5] [Ref-6] for the main lighting and other loads required during maintenance operations,

Each of the 10 kV main switchboards receives power from a 10 kV main switchboard of the conventional island; the switching device is installed on the conventional island.

The low voltage boards receive their power supply via a circuit breaker at the 10 kV level that provides electrical protection functions in the event of failure on the low voltage busbars.

The dry type low voltage transformers are directly connected to the low voltage busbars.

The faults are indicated locally and on the PICS, and an alarm is triggered when an action is necessary.

Design parameters:

See section 5.1.3 of this sub-chapter.

6.4. OPERATIONAL REQUIREMENTS

The 10 kV main switchboards receive their power from the 10 kV main switchboards on the conventional island during normal operation, start-up and normal shutdown of the unit as well as during unit outages.

6.5. TESTS, INSPECTION AND MAINTENANCE

The 690 V main distribution boards located in divisions 1 and 4 receive their power from the 10 kV distribution boards on the conventional island, section 1 and 4. These switchboards are required to be available during unit shutdowns and during maintenance operations on the conventional island, in order to supply power to loads such as the operational chilled water, the spent fuel pool water treatment plant or the reactor building ventilation system. There is no interconnection on the nuclear island, but the 10 kV busbars on the conventional island that provide the 690 V normal power supply to the nuclear island may be re-supplied with power from the neighbouring train (by use of a transportable circuit breaker).

See Sub-chapter 8.3 - Figure 2: interconnection 6 on the conventional island for the 690 V main sub-distribution boards

The 400 V AC main sub-distribution boards supply power to loads such as the main lighting, electrical outlets, hoists, cranes and main ventilation, that are necessary during unit shutdown or preventive maintenance operations. There are interconnections between the sub-distributions of divisions 1 and 2, and divisions 3 and 4 respectively. They will only be used during a maintenance period and are closed by manually-controlled fused switch isolators.

See Sub-chapter 8.3 - Figure 2: interconnection 4 for the 400 V AC main sub-distributors.

7. IMPLEMENTATION OF QUALIFICATION OF ELECTRICAL EQUIPMENT FOR NORMAL AND ACCIDENTAL CONDITIONS

7.1. INTRODUCTION

This section provides a set of safety requirements which have been specified for equipment qualification. The conditions taken into account to meet all the safety requirements are defined in order to ensure that Structures, Systems and Components (SSC) important to safety will perform their required safety function(s) throughout their operational lives in the specified environmental conditions.

7.2. IMPLEMENTATION OF QUALIFICATION

In order to prove that the qualification of electrical equipment fully meets all the functionality, performance and integrity requirements, a strategy is implemented in the design of electrical systems and associated equipment. This strategy is based on different claims:

- the qualification procedures should demonstrate a level of confidence commensurate with their safety classification;
- the operational, environmental and fault conditions specified in the design (including severe accidents where appropriate) are addressed within the procedures for the qualification of equipment;
- the procedures should include a substantiated demonstration that individual items can perform their safety function(s) under the required conditions;
- to preserve qualification (arrangements made during manufacturing, installation and operation).

From the Book of Technical Specifications (e.g. [Ref-1] to [Ref-5]) and the Book of Specific Technical Clauses, type tests will ensure that the UK EPR electrical system equipment performs its safety functions under the required conditions.

7.2.1. Qualification Procedure Confidence

The qualification procedures should demonstrate a level of confidence commensurate with their safety classification.

All equipment implemented in class 1, class 2 and class 3 systems are identified and the qualification requirements stated (see definition of safety classes in Sub-chapter 3.2):

At the generic design stage the safety classes and qualification requirements are identified (see Sub-chapter 3.6).

During site licensing, the licensee has to provide the list of equipment contributing to the safety functions, the equipment location, and the associated qualification requirements.

The safety classification gradation in the qualification procedure decreases as follows:

- all equipment implemented in class 1, class 2 and class 3 systems are qualified to the environmental conditions except earthquake;
- all equipment implemented in class 1 and class 2 systems are qualified for earthquake;
- equipment implemented in class 3 systems is qualified for earthquake on a case by case analysis.

7.2.1.1 Conditions governing authorisation to use an item of equipment in class 1, class 2 and class 3 systems

The level of confidence is based on the fulfilment of several conditions:

- **Condition 1:** The equipment shall be deemed suitable for the application(s) for which it is intended. Suitability is determined on the basis of the equipment qualification procedure.

At the generic design stage, the qualification method and procedures are specified according to chapter B 2000 of the AFCEN RCC-E code [Ref-1] and in equipment technical specifications respectively.

During site licensing, the licensee must guarantee the performance of each item of equipment through qualification and issue the qualification report;

- **Condition 2:** The manufacturer shall be deemed competent to undertake series production of equipment in conformity with the qualified model. Competence is determined on the basis of the manufacturing evaluation procedure.

At the generic design stage, the evaluation procedure is specified according to chapter B 1200 of the AFCEN RCC-E code [Ref-1].

During site licensing, the licensee is responsible for ensuring the performance of each supplier / equipment evaluation;

- **Conditions 1 and 2** are required to issue authorisation for the use of series-produced equipment conforming to a qualification model. Equipment qualification and manufacturing evaluation procedures may be carried out simultaneously.

At the generic design stage, the authorisation procedure is specified in accordance with chapter B 1300 of the AFCEN RCC-E code [Ref-1].

During site licensing, the licensee must implement the authorisation procedure for each supplier and piece of equipment;

- **Condition 3:** Conformity with the model shall be maintained throughout the series production period. This conformity is verified by subjecting the manufacturing process to the follow-up procedure for approved equipment.

At the generic design stage, the follow-up procedure for approved equipment is specified in accordance with chapter B 1400 of the AFCEN RCC-E code [Ref-1].

During site licensing, the licensee must implement the follow-up procedure for all equipment.

7.2.1.2 Compliance with operational, environmental and fault conditions

The operational, environmental and fault conditions specified in the design (including severe accidents where appropriate) are addressed within the procedures for the qualification of equipment.

The requirements to enable equipment operation are specified and documented for all applicable environmental conditions.

At the generic design stage, the service and use conditions, for which the equipment has to be qualified, are specified in chapter B 2210 of the AFCEN RCC-E code [Ref-1]. Chapter B 2230 of the AFCEN RCC-E code [Ref-1] defines how the requirements of chapter B 2110 of [Ref-1] will be met.

During site licensing, these requirements are specified in the equipment technical specifications and later in the equipment qualification programme and equipment qualification specifications.

The environmental conditions are broken down into ranges specified in Sub-chapter 3.6. The choice of equipment associated with a range of environmental and/or earthquake conditions depends on equipment location.

At the generic design stage, only the range of environmental conditions is provided in chapter D 2200 of the AFCEN RCC-E code [Ref-1] and the Book of Project Data [Ref-2]. The content of the qualification report is specified in chapter B 2500 of the AFCEN RCC-E Code [Ref-1].

During site licensing, the licensee will provide the relevant environmental conditions in chapter 8 of the equipment technical specification that describes the overall tests (e.g. Isc rating, seismic tests, etc.). The qualification report proves that the equipment is capable of fulfilling its duty in the required environmental conditions without ambiguity.

7.2.2. Performance of Safety Equipment

The procedures should include a physical demonstration that individual items can perform their safety function(s) under the required conditions, and within the time substantiated in the facility safety case.

7.2.2.1 Qualification methods

To qualify equipment several methods are available and acceptable:

- qualification by testing;
- qualification by analysis, including analogy, calculation and operating experience qualifications;
- combined qualification (mixed methods).

At the generic design stage, several acceptable methods for equipment qualification are listed in chapter B 2300 of the AFCEN RCC-E code [Ref-1]. A preferred solution is specified in chapter B 2600 of the AFCEN RCC-E code [Ref-1].

During site licensing, the licensee will provide a description of the chosen qualification method for each item of equipment.

7.2.2.2 Applicable qualification programmes

The hardware qualification programme identifies the qualification method used and the qualification specifications and criteria. In accordance with equipment location and safety classification, one or several of the following procedures are used:

- the qualification for normal ambient operating conditions;
- the seismic qualification of equipment and/or Ambient Degraded;
- the irradiation qualification;
- the Loss of Coolant Accident (LOCA) qualification;
- the severe accident qualification.

At the generic design stage, the requirements are provided in chapters B 3000 to B 7000 of the AFCEN RCC-E code respectively [Ref-1].

During site licensing, the equipment qualification programme, the specific equipment qualification specification and the qualification report provide the relevant updated data throughout the project.

At the generic design stage, the smart device software functional verification programme is defined in the chapter C 5333 of the AFCEN RCC-E code [Ref-1].

During site licensing, all smart devices will be identified and tracked and their software verified, (see Sub-chapter 8.6).

7.2.2.3 Stresses

The performance of equipment has to be assessed under the following environmental conditions:

- pressure, temperature, humidity envelop conditions under normal and accidental events;
- ageing and accident irradiations, Note: If equipment is not sensitive, irradiation is not taken into account for qualification;
- seismic conditions.

At the generic design stage, the chapter D 2200 of the Book of Project Data [Ref-1] provides bounding conditions.

Depending on the equipment location, Sub-chapter 3.6 provides:

- the conditions to be used for accident environmental conditions, excluding severe accidents;
- the conditions to be used for harsh environmental conditions for use in severe accidents;
- design data for environmental conditions, and the seismic spectra used for qualification.

During site licensing, the consistency of environmental qualification data will be confirmed.

The performance of equipment has to be assessed under the variation of at least the following electrical parameter variations:

- power supply and frequency in the ranges of chapter D 2300 of the AFCEN RCC-E code [Ref-2];
- electromagnetic immunity and susceptibility withstand capability as defined in the equipment technical specification based on the project EMC requirements chapter D 5000 of the AFCEN RCC-E code [Ref-2].

At the generic design stage, the tests applicable for the respective electrical equipment are provided by chapter 8 of the equipment technical specification based on IEC and industrial standards. Examples of tests usually carried out are listed below:

- dielectric tests to determine the dielectric properties of the electrical equipment;
- measurements of the resistance of the circuits;
- temperature-rise tests to determine the behaviour of the different materials to each other;
- verification of the degree of the protection class.

Some special tests for different electrical equipment are:

- tests of the short time withstand current and the peak short-circuit currents;
- short circuit tests;
- tests of internal arcing fault conditions for switchgear.

At the generic design stage, the equipment technical specification defines the location and stresses applicable to the equipment. A description of the content of the equipment technical specification will be provided.

During site licensing, the equipment technical specification and the tests report will be provided.

7.2.3. Arrangements Made to Preserve Qualification

The procedures should ensure that adequate arrangements exist for the recording and retrieval of lifetime data covering equipment construction, manufacture, testing, inspection and maintenance to demonstrate that any assumptions made in the safety case remain valid throughout operational life.

7.2.3.1 During manufacturing

This topic has been addressed in section 7.2.1.1 (Condition 3).

7.2.3.2 During installation and operation

The equipment will be installed and maintained during its lifetime to preserve its initial qualification.

At the generic design stage, the aims of the qualification maintenance process during installation and operation and the qualification preservation sheet are described (see Sub-chapter 3.6).

During site licensing, the same qualification preservation sheet describes the arrangements made to preserve qualification. The arrangements will address the positive maintenance actions required to preserve the qualification, the precautions required when conducting the maintenance to prevent any adverse affect on the validity of the qualification and the re-validation tests required upon completion of the maintenance to confirm that no such adverse affect has been introduced.

7.2.3.3 In-service management

The long-term qualification of equipment will be enhanced by arrangements established by the licensee to address both equipment ageing and obsolescence issues, including recording the operating conditions to ensure that the operational environment of the electrical distribution system is within defined limits. The actual approach will be clarified during site licensing.

SUB-CHAPTER 8.3 - FIGURE 1

Single line diagram [Ref-1]

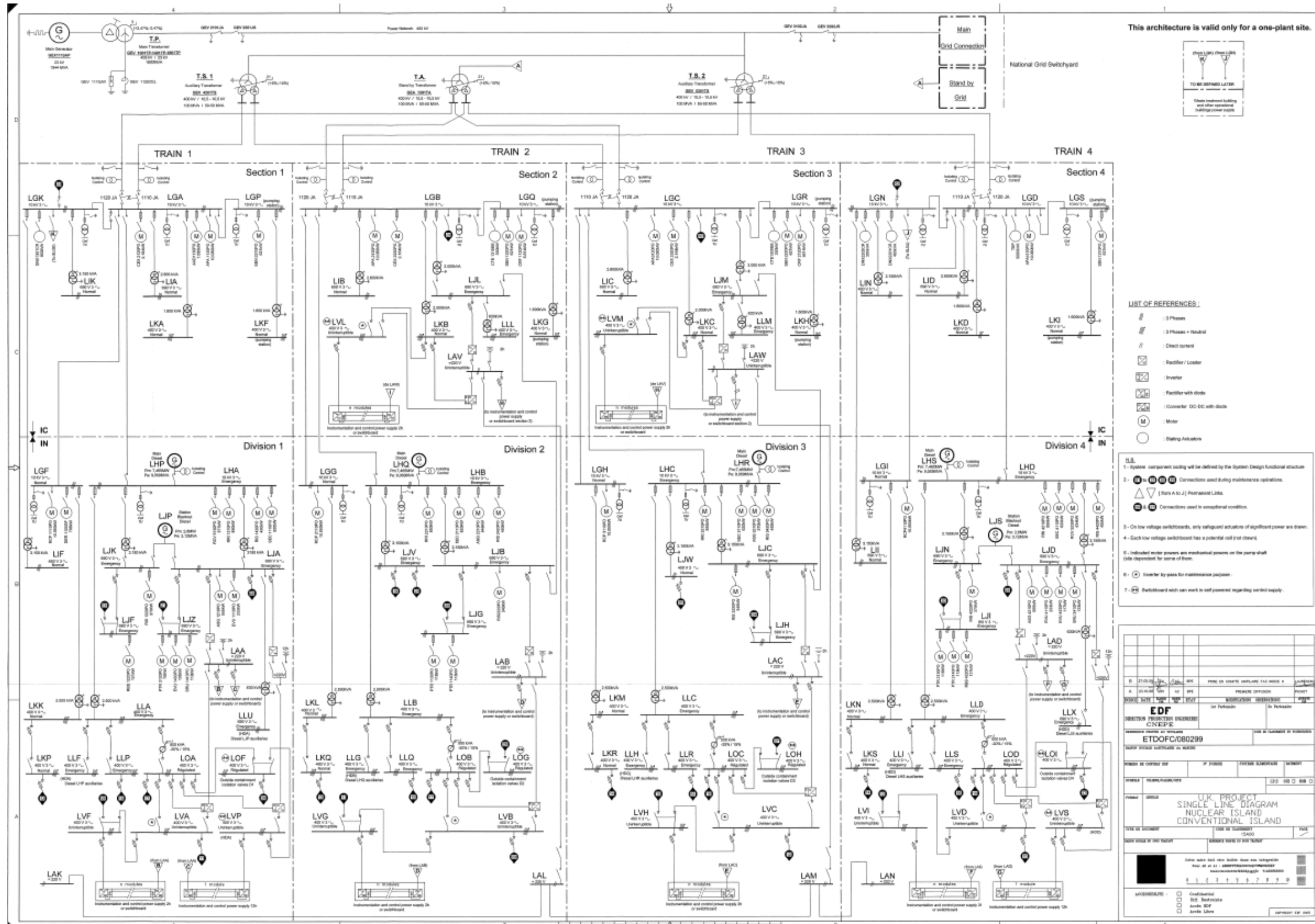

SUB-CHAPTER 8.3 - FIGURE 2

Schematic diagram of divisions 1 and 2 with the supply to the I&C cabinets and the electrical interconnections

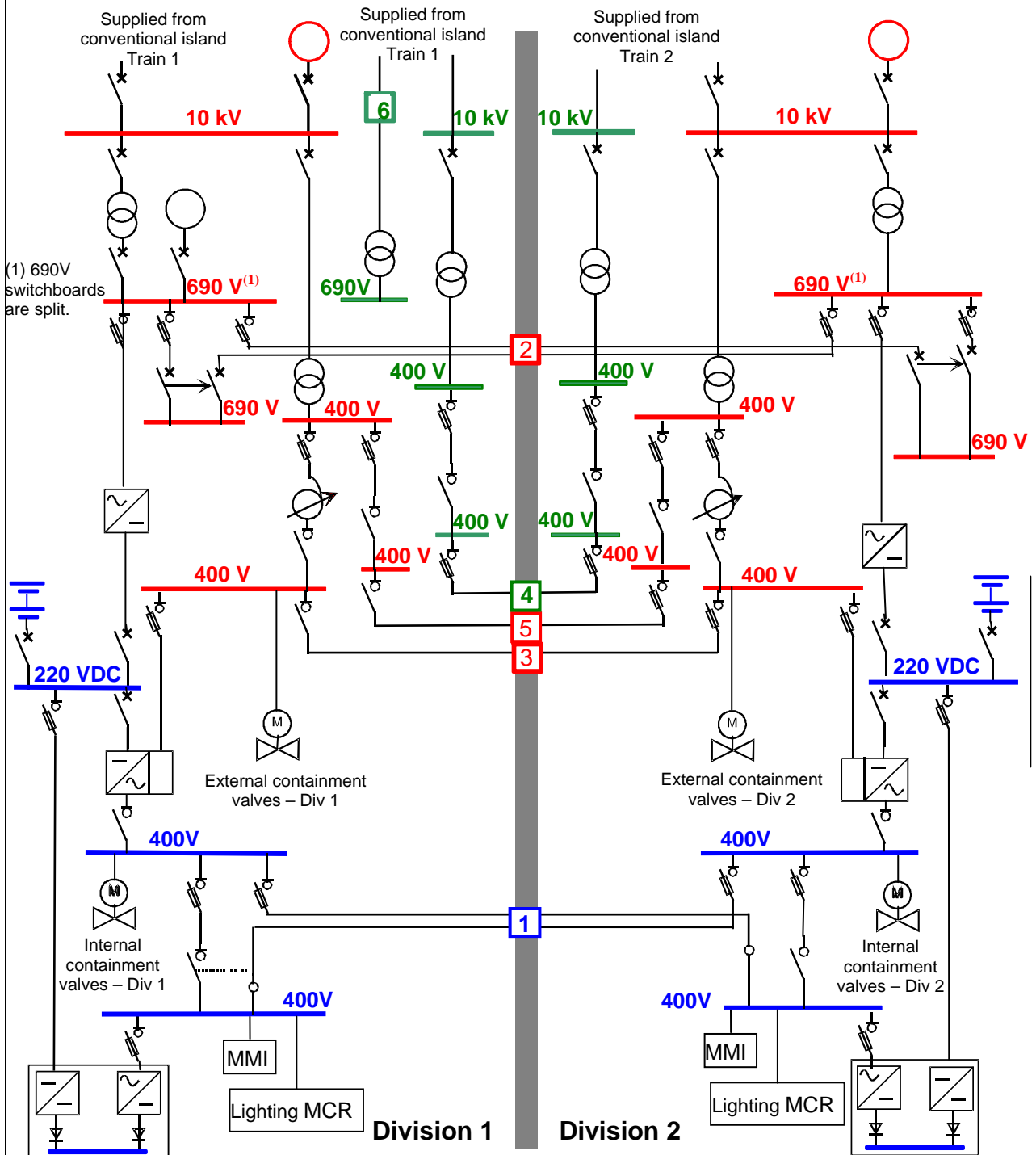

List of the interconnections

- | | |
|--|--|
| <p>1 For I&C cabinets</p> <p>2 For PTR [FPCS] system</p> <p>3 For regulated 400 V AC</p> | <p>4 For main 400 V AC</p> <p>5 For emergency-supplied 400 V AC</p> <p>6 For main 690 V AC of the NI</p> |
|--|--|

I&C cabinets and switchboards control Division 1

I&C cabinets and switchboards control Division 2

SUB-CHAPTER 8.3 - FIGURE 3

Power supply to rod control mechanisms

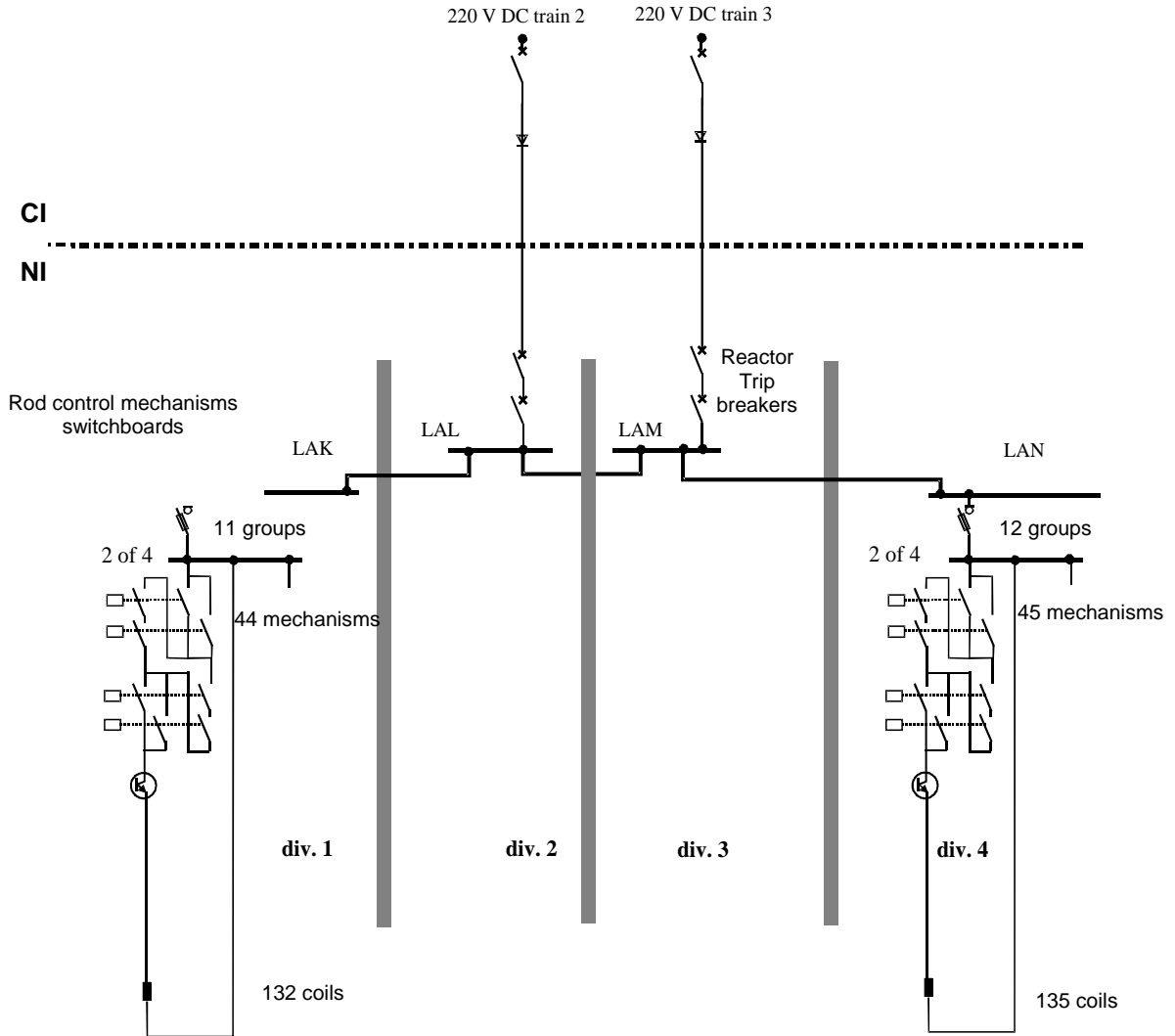

SUB-CHAPTER 8.3 - FIGURE 4

Principles of the power supply to the containment valves

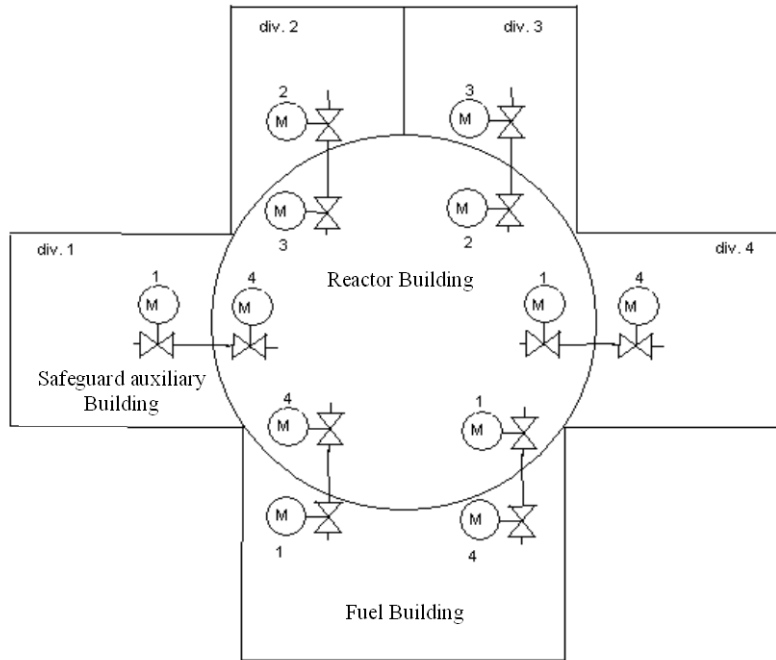

SUB-CHAPTER 8.3 – REFERENCES

External references are identified within this sub-chapter by the text [Ref-1], [Ref-2], etc at the appropriate point within the sub-chapter. These references are listed here under the heading of the section or sub-section in which they are quoted.

0. SAFETY REQUIREMENTS

0.3. DESIGN REQUIREMENTS

0.3.1. Requirements arising from Safety Classification

[Ref-1] Design and Construction Rules for Electrical Components of Nuclear Islands. RCC-E. AFCEN Edition. December 2005. (E)

0.4. SAFETY CASE RELATIONSHIP

[Ref-1] UKEPR GDA Electrical System CAE Document. 17074-709-000-RPT-0002 Issue 05. October 2012. (E)

1. SYSTEM ARCHITECTURE

[Ref-1] System Design Manual – 10 kV Normal Power Supply System (Conventional Island) (LGi), Part 2 – System operation. ETDOFC080180 Revision A1. EDF. September 2009. (E)

[Ref-2] System Design Manual – 10 kV Emergency Power Supply System (LHi), Part 2 – System operation (Stage 2). EZE/2007/en/0036 Revision D. EDF. October 2008. (E)

[Ref-3] System Design Manual. LK – 400 V Normal Distribution System (Conventional Island), Part 2 – System Operation. ETDOFC080199 Revision A1. EDF. October 2009. (E)

[Ref-4] Design and Construction Rules for Electrical Components of Nuclear Islands. RCC-E. AFCEN Edition. December 2005. (E)

[Ref-5] Book of Project Data completing the RCC-E December 2005 requirements for the EPR. ENSEMD050222 Issue C. May 2007. (E)

2. EMERGENCY DIESEL GENERATORS

2.2. DESIGN BASIS

- [Ref-1] System Design Manual 10 kV Diesel Generator Set Division 1/2/3/4 (LHP/Q/R/S), Part 2 – System operation (Stage 2). EYTS/2007/fr/0002 Revision B1. Sofinel. October 2009. (E)
- [Ref-2] System Design Manual 10 kV Diesel Generator Set Division 1/2/3/4 (LHP/Q/R/S), Part 3 – System sizing (Stage 2). EYTS/2008/fr/0041 Revision A1. Sofinel. October 2009. (E)
- [Ref-3] System Design Manual 10 kV Diesel Generator Set Division 1/2/3/4 (LHP/Q/R/S), Part 5 - Instrumentation and Control (Stage 2). EYTS/2007/fr/0164 Revision B1. Sofinel. October 2009. (E)
- [Ref-4] Design and Construction Rules for Electrical Components of Nuclear Islands. RCC-E. AFCEN Edition. December 2005. (E)
- [Ref-5] Main diesel generator design basis – Functional requirements justification. ECEF060691 Revision B1. EDF. March 2010. (E)
- ECEF060691 Revision B1 is the English translation of ECEF060691 Revision B.

3. ULTIMATE DIESEL GENERATORS

3.2. DESIGN BASIS

- [Ref-1] Functional justification of SBO diesel generator design basis. ECEF060964 Revision B1. EDF. April 2010. (E)
- [Ref-2] System Design Manual 690 V Emergency Diesel Generators (LJP/S), Part 3 – System sizing (Stage 2). EYTS/2008/fr/0068 Revision B1. Sofinel. October 2009. (E)
- [Ref-3] System Design Manual 690 V Emergency Diesel Generators (LJP/S), Part 5 – Instrumentation and Control (Stage 2). EYTS/2008/fr/0034 Revision B1. Sofinel. October 2009. (E)

4. DIFFERENCES BETWEEN EMERGENCY DIESEL GENERATORS AND ULTIMATE DIESEL GENERATORS

- [Ref-1] Independence of the EDG/UDG on EPR FA3 n° ECEMA091072 A. EDF. July 2009. (E)

5. EMERGENCY POWER SUPPLIES

5.1. MEDIUM AND LOW VOLTAGE INTERRUPTIBLE EMERGENCY POWER SUPPLIES

5.1.2. Design Basis

[Ref-1] Design and Construction Rules for Electrical Components of Nuclear Islands. RCC-E. AFCEN Edition. December 2005. (E)

5.1.3. System Description – Design Parameters

[Ref-1] System Design Manual – 10 kV Emergency Power Supply System (LHi), Part 2 – System Operation (Stage 2).
EZE/2007/en/0036 Revision D. EDF. October 2008. (E)

[Ref-2] System Design Manual - 10 kV Emergency Power Supply System (LHi), Part 5 - Instrumentation and Control (Stage 2).
EZE/2007/en/0045 Revision D. EDF. October 2008. (E)

[Ref-3] System Design Manual – 690 V Emergency Power Supply System (LJi), Part 2 – System operation (Stage 2).
EZE/2007/en/0010 Revision C. EDF. December 2008. (E)

[Ref-4] System Design Manual – 690 V Emergency Power Supply System (LJi), Part 5 - Instrumentation and Control (Stage 2).
EZE/2007/en/0019 Revision D. EDF. October 2008. (E)

[Ref-5] System Design Manual – 400 V Regulated Emergency Power Supply System in the Nuclear Island (LOi),
Part 2 – System operation (Stage 2).
EZE/2007/en/0006 Revision C. EDF. December 2008. (E)

[Ref-6] System Design Manual – 400 V Regulated Emergency Power Supply System in the Nuclear Island (LOi),
Part 5 - Instrumentation and Control (Stage 2).
(P5) EZE/2007/en/0021 Revision D. EDF. October 2008. (E)
(P5.6) EZE/2007/en/0049 Revision D. EDF. October 2008. (E)

[Ref-7] System Design Manual – 400 V Emergency Power Supply System (LLi),
Part 2 – System operation (Stage 2).
EZE/2007/en/0007 Revision C. EDF. December 2008. (E)

[Ref-8] System Design Manual – 400 V Emergency Power Supply System (LLi),
Part 5 - Instrumentation and Control (Stage 2).
EZE/2007/en/0020 Revision D. EDF. October 2008. (E)

[Ref-9] Design and Construction Rules for Electrical Components of Nuclear Islands. RCC-E. AFCEN Edition. December 2005. (E)

5.2. UNINTERRUPTIBLE POWER SUPPLY

5.2.1. 2-Hour Uninterruptible Power Supply

5.2.1.1. Operating role

[Ref-1] System Design Manual - 2 hour 220 VDC Uninterruptible Power Supply System in the Nuclear Island (LAA/B/C/D), Part 2 – System operation (Stage 2).
EZE/2007/en/0035 Revision B. EDF. October 2008. (E)

[Ref-2] System Design Manual - 2 hour and 12 hour Uninterruptible Power Supply System (LVi), Part 2 – System operation (Stage 2).
EZE/2007/en/0026 Revision C. EDF. October 2008. (E)

5.2.1.2. Design basis

[Ref-1] Design and Construction Rules for Electrical Components of Nuclear Islands. RCC-E. AFCEN Edition. December 2005. (E)

[Ref-2] Functional scenarios considered in the design of the EPR Nuclear Island Batteries
ECEFO90881 Revision A1. EDF. January 2010. (E)

ECEFO90881 Revision A1 is the English translation of ECEFO90881 Revision A.

5.2.1.3. System description – design parameters

[Ref-1] System Design Manual - 2 hour and 12 hour Uninterruptible Power Supply System (LVi), Part 2 – System operation (Stage 2).
EZE/2007/en/0026 Revision C. EDF. October 2008. (E)

[Ref-2] System Design Manual - 2 hour and 12 hour Uninterruptible Power Supply System (LVi), Part 5 - Instrumentation and Control (Stage 2).
EZE/2007/en/0029 Revision B. EDF. October 2008. (E)

[Ref-3] System Design Manual - 2 hour 220 V DC Uninterruptible Power Supply System in the Nuclear Island (LAA/B/C/D), Part 2 – System operation (Stage 2).
EZE/2007/en/0035 Revision B. EDF. October 2008. (E)

[Ref-4] System Design Manual - 2 hour 220 V DC Uninterruptible Power Supply System in the Nuclear Island (LAA/B/C/D), Part 5 - Instrumentation and Control (Stage 2).
EZE/2007/en/0039 Revision B. EDF. October 2008. (E)

5.2.2. Power Supply to Rod Control Mechanisms

5.2.2.3. System description – design parameters

[Ref-1] System Design Manual 2 hour 220 V DC Uninterruptible Power Supply System (LAV/W), Part 2 – System operation (Stage 2). ETDOFC080062 Revision A1. EDF. November 2009. (E)

[Ref-2] System Design Manual 2 hour 220 V DC Uninterruptible Power Supply System (LAV/W), Part 3 – System sizing (Stage 2). ETDOFC080260 Revision A1. EDF. November 2009. (E)

[Ref-3] System Design Manual 2 hour 220 V DC Uninterruptible Power Supply System (LAV/W), Part 4 – Flow Diagrams (Stage 2). ETDOFC080264 Revision A1. EDF. September 2009. (E)

[Ref-4] System Design Manual 2 hour 220 V DC Uninterruptible Power Supply System (LAV/W), Part 5 - Instrumentation and Control (Stage 2). ETDOFC070283 Revision C1. EDF. November 2009. (E)

5.2.3. Severe Accident Dedicated 12-Hour Uninterruptible Power Supply

5.2.3.1. Operating role

[Ref-1] System Design Manual - 2 hour and 12 hour Uninterruptible Power Supply System (LVi), Part 2 – System operation (Stage 2). EZE/2007/en/0026 Revision C. EDF. October 2008. (E)

5.2.3.2. Design basis

[Ref-1] Design and Construction Rules for Electrical Components of Nuclear Islands. RCC-E. AFCEN Edition. December 2005. (E)

[Ref-2] System Design Manual - 2 hour and 12 hour Uninterruptible Power Supply System (LVi), Part 2 – System operation (Stage 2). EZE/2007/en/0026 Revision C. EDF. October 2008. (E)

[Ref-3] System Design Manual - 2 hour and 12 hour Uninterruptible Power Supply System (LVi), Part 5 - Instrumentation and Control (Stage 2).] EZE/2007/en/0029 Revision B. EDF. October 2008. (E)

[Ref-4] Functional scenarios considered in the design of the EPR Nuclear Island Batteries ECEF090881 Revision A1. EDF. January 2010. (E)

5.2.3.3. System description – design parameters

[Ref-1] System Design Manual - 2 hour and 12 hour Uninterruptible Power Supply System (LVi), Part 2 – System operation (Stage 2). EZE/2007/en/0026 Revision C. EDF. October 2008. (E)

[Ref-2] System Design Manual - 2 hour and 12 hour Uninterruptible Power Supply System (LVi), Part 5 - Instrumentation and Control (Stage 2).] EZE/2007/en/0029 Revision B. EDF. October 2008. (E)

5.2.3.4. Operational requirements

[Ref-1] System Design Manual – 400 V Regulated Emergency Power Supply System in the Nuclear Island (LOi), Part 2 – System operation (Stage 2). EZE/2007/en/0006 Revision C. EDF. December 2008. (E)

- [Ref-2]** System Design Manual – 400 V Regulated Emergency Power Supply System in the Nuclear Island (LOi),
Part 5 - Instrumentation and Control (Stage 2).
(P5) EZE/2007/en/0021 Revision D. EDF. October 2008. (E)
(P5.6) EZE/2007/en/0049 Revision D. EDF. October 2008. (E)

5.2.3.5. Tests, inspection and maintenance

- [Ref-1]** The Equipment Reliability Process Description. INPO AP-913 Revision 1. Institute of Nuclear Power Operators. November 2001. (E)

6. NORMAL ELECTRICAL DISTRIBUTION SYSTEM

6.3. SYSTEM DESCRIPTION – DESIGN PARAMETERS

- [Ref-1]** System Design Manual – 10 kV Normal Power Supply System (Nuclear Island) (LGF/G/H/I), Part 2 – System operation (Stage 2).
EZE/2008/en/0003 Revision D. EDF. October 2008. (E)
- [Ref-2]** System Design Manual - 10 kV Normal Power Supply System (Nuclear Island) (LGF/G/H/I), Part 5 - Instrumentation and Control (Stage 2).
EZE/2007/en/0042 Revision D. EDF. October 2008. (E)
- [Ref-3]** System Design Manual – 690 V Normal Distribution System (Nuclear Island) (LIF/LII), Part 2 – System operation (Stage 2).
EZE/2007/en/0055 Revision B. EDF. December 2008. (E)
- [Ref-4]** System Design Manual – 690 V Normal Distribution System (Nuclear Island) (LIF/LII), Part 5 - Instrumentation and Control (Stage 2).
EZE/2007/en/0053 Revision D. EDF. October 2008. (E)
- [Ref-5]** System Design Manual – 400 V Normal Distribution System (Nuclear Island) (LKi), Part 2 – System operation (Stage 2).
EZE/2007/en/0038 Revision B. EDF. December 2008. (E)
- [Ref-6]** System Design Manual – 400 V Normal Distribution System (Nuclear Island) (LKi), Part 5 - Instrumentation and Control (Stage 2).
EZE/2007/en/0052 Revision D. EDF. October 2008. (E)

7. IMPLEMENTATION OF QUALIFICATION OF ELECTRICAL EQUIPMENT FOR NORMAL AND ACCIDENTAL CONDITIONS

7.2. IMPLEMENTATION OF QUALIFICATION

- [Ref-1]** Book of Technical Specifications (BTS). MV Switchboards for Nuclear Power Plants. 74.C.022.04. EDF. April 2004. (E)

- [Ref-2] Technical Specifications - Low Voltage Switchboards (380 V, 400 V and 690 V) for Nuclear Power Stations General Clauses. 74.C.023.02. EDF. March 2004. (E)
- [Ref-3] Technical Specifications (TS) - Control Source Switchboards for Nuclear Power Stations. 74.C.032.02. EDF. March 2004. (E)
- [Ref-4] Book of Technical Specifications (BTS) - Batteries Chargers / Rectifiers for Nuclear Power Plants - General Clauses. 76.C.001.03. EDF. October 2004. (E)
- [Ref-5] Book of Technical Specifications (BTS) - Stationary Accumulator Batteries for Nuclear Power Plants. 76.C.017.02. EDF. November 2004. (E)

7.2.1. Qualification Procedure Confidence

7.2.1.1. Conditions governing authorisation to use an item of equipment in class 1, class 2 and class 3 systems

- [Ref-1] Design and Construction Rules for Electrical Components of Nuclear Islands. RCC-E. AFCEN Edition. December 2005. (E)

7.2.1.2. Compliance with operational, environmental and fault conditions

- [Ref-1] Design and Construction Rules for Electrical Components of Nuclear Islands. RCC-E. AFCEN Edition. December 2005. (E)
- [Ref-2] Book of Project Data completing the RCC-E December 2005 requirements for the EPR. ENSEMD050222 Revision C. EDF. May 2007. (E)

7.2.2. Performance of Safety Equipment

7.2.2.1. Qualification methods

- [Ref-1] Design and Construction Rules for Electrical Components of Nuclear Islands. RCC-E. AFCEN Edition. December 2005. (E)

7.2.2.2. Applicable qualification programmes

- [Ref-1] Design and Construction Rules for Electrical Components of Nuclear Islands. RCC-E. AFCEN Edition. December 2005. (E)

7.2.2.3. Stresses

- [Ref-1] Book of Project Data completing the RCC-E December 2005 requirements for EPR. ENSEMD050222 Revision C. EDF. May 2007. (E)
- [Ref-2] Design and Construction Rules for Electrical Components of Nuclear Islands. RCC-E. AFCEN Edition. December 2005. (E)

SUB-CHAPTER 8.3 - FIGURE 1

[Ref-1] UK Project - Single Line Diagram Nuclear Island Conventional Island. ETD0FC080299
Revision B. EDF. June 2009. (E)